



⚠ WARNING ⚠

TO REDUCE RISK OF SERIOUS INJURY OR PROPERTY DAMAGE:
READ ALL SAFETY MESSAGES AND UNDERSTAND ALL INSTRUCTIONS AND PROCEDURE
NOTICES BEFORE ATTEMPTING TO INSTALL OR USE THIS PRODUCT.

⚠ CAUTION ⚠

RISK OF EYE INJURY! SAFETY GLASSES MUST BE WORN AT ALL TIMES WHILE INSTALLING
OR MAINTAINING THIS PRODUCT. DO NOT USE IF DAMAGED.

A FEW WORDS ABOUT PRODUCT SAFETY:

Your Lost Canyon Base Camp Bed Rack is intended to enhance the utility and enjoyment of your off-road capable Gladiator. Follow all safety information and installation recommendations. Throughout these instructions is important safety information that is generally preceded by one of three signal words indicating the relative risk of injury, property damage or adverse consequence.

The signal words mean:

⚠ WARNING ⚠

A HAZARDOUS SITUATION WHICH, IF NOT AVOIDED, COULD RESULT IN DEATH OR SERIOUS INJURY. YOU CAN BE KILLED OR SERIOUSLY HURT IF YOU DON'T FOLLOW INSTRUCTIONS.

⚠ CAUTION ⚠

A HAZARDOUS SITUATION WHICH, IF NOT AVOIDED, COULD RESULT IN A MINOR OR MODERATE INJURY. YOU CAN BE MODERATELY HURT AND ALSO MAY SUFFER PROPERTY DAMAGE IF YOU DON'T FOLLOW INSTRUCTIONS.

NOTICE

CAREFUL ATTENTION IS REQUIRED TO THIS INSTRUCTION OR OPERATION BUT DOES GENERALLY NOT RELATE TO PERSONAL INJURY. DAMAGE TO YOUR LOST CANYON PRODUCT OR OTHER PROPERTY MAY RESULT IF YOU DON'T FOLLOW INSTRUCTIONS.

BEFORE YOU BEGIN USAGE:

Congratulations on your purchase of the Lost Canyon Base Camp Bed Rack. When unpacking, check to make sure all parts are included and not damaged due to shipping. If any part is missing or broken, please call Customer Service at 800-745-6037 as soon as possible. Thank you again for your purchase.

⚠ WARNING ⚠

DO NOT EXCEED THE VEHICLE MANUFACTURE'S WEIGHT LIMITS

⚠ WARNING ⚠

DO NOT EXCEED THE MAXIMUM LOAD OF 500LBS DYNAMICALLY AND 800LBS STACTILY FOR THE BED RACK, THIS IS NOT THE VEHICLE'S MAXIMUM LOAD CAPACITIES, THIS IT THE CAPACITY FOR THE BED RACK.
MAX VEHICLE LOAD = WEIGHT OF ROOF RACK + WEIGHT OF ACCESSORIES + WEIGHT OF LOAD

⚠ WARNING ⚠

INSTALLATION OF THIS PRODUCT WILL MODIFY THE VEHICLE'S MAXIMUM PAYLOAD. THE VEHICLE MAY HANDLE DIFFERENTLY THAN AS FACTORY-EQUIPED INCLUDING; DECREASING RIDE-HEIGHT; REDUCED LATERAL STABILITY; CHANGE THE VEHICLE'S CENTER OF GRAVITY; AND HIGHER RISK OF ROLL-OVER OR OTHER ACCIDENT. ADDITIONALLY IN COMBINATION WITH OTHER VEHICLE MODIFICATIONS INCREASE RISK

⚠ WARNING ⚠

LOADS SHOULD BE UNIFORMLY DISTRIBUTED WITH THE LOWEST POSSIBLE CENTER OF GRAVITY, AND LOADS SHOULD NOT SUBSTANTIALLY EXTEND BEYOND THE LOADING SURFACE OF THE BED RACK

⚠ WARNING ⚠

INADEQUATEDLY SECURED LOADS AND INCORRECTLY MOUNTED BED RACKS AND ACCESSORIES CAN COME LOOSE DURING TRAVEL AND CAUSE SERIOUS INJURY. FOR YOUR SAFETY AND OTHERS YOU SHOULD ONLY USE THIS BED RACK ON JEEP GLADIATOR VEHICLES WHICH IT IS SPECIFICALLY DESIGNED TO FIT.

⚠ WARNING ⚠

DO NOT CUT OR MODIFY THE BED RACK OR MOUNTING ACCESSORIES IN ANY WAY.

⚠ CAUTION ⚠

COMPONENTS MAY HAVE SHARP EDGES, GLOVES MUST BE WORN AT ALL TIMES WHILE INSTALLING OR MAINTAINING THIS PRODUCT. DO NOT USE IF DAMAGED. EXTREME CARE NEEDS TO BE TAKEN TO AVOID INJURY OR DAMAGE TO BED COMPONENTS AND PAINT DURING USE AND INSTALLATION OF THIS PRODUCT.

⚠ CAUTION ⚠

CHECK MOUNTING HARDWARE AND ACCESSORY MOUNTING HARDWARE AFTER A SHORT DISTANCE FOLLOWING THE INSTALLATION OF THE BED RACK, AT A REGULAR INTERVAL, OR BEFORE THE START OF A LONG JOURNEY.

⚠ CAUTION ⚠

REGULAR INSPECTION OF DAMAGE TO THE BED RACK FROM OUTSIDE FORCES IS IMPORTANT AND DO NOT USE RACK IF DAMAGED. REPLACE PARTS AS NEEDED, USE ONLY ORIGINAL SPARE PARTS OBTAINED FROM LOST CANYON'S CUSTOMER SERVICE.

⚠ CAUTION ⚠

VEHICLE SPEED MUST BE ADJUSTED AND SUITED TO THE LOAD BEING TRANSPORTED AND TO POSTED SPEED LIMITS.

⚠ CAUTION ⚠

FOR REASONS OF FUEL ECONOMY AND THE SAFETY OF OTHER ROAD USERS, THE BED RACK SHOULD BE REMOVED WHEN NOT IN USE.

NOTICE

ANY CHANGES MADE TO THE BED RACK AND ACCESSORIES AS WELL AS THE USE OF SPARE PARTS OTHER THEN THOSE SUPPLIED BY THE MANUFACTURE WILL LEAD TO THE LAPSING OF THE MANUFACTURES WARRANTY AND LIABILITY FOR ANY MATERIAL DAMAGE OR ACCIDENT. YOU SHOULD OBSERVE THES INSTRUCTIONS TO THE LETTER AND ONLY USE THE ORIGINAL PARTS SUPPLIED.

⚠ CAUTION ⚠

READ ALL SAFETY MESSAGES AND ALWAYS WEAR SAFETY GLASSES WHEN WORKING WITH TOOLS.

Kit Contents

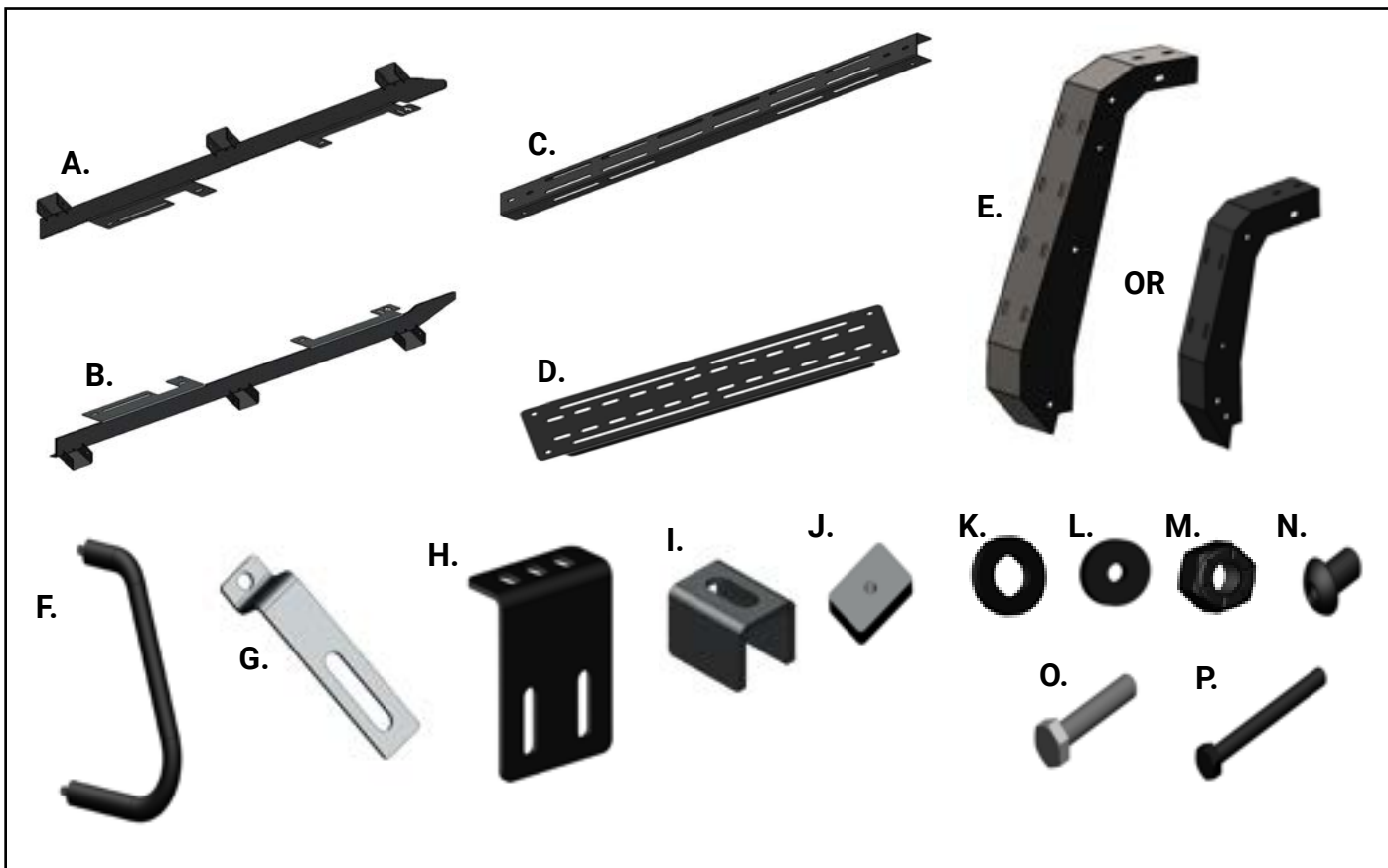

KIT CONTENT LIST:

- A. Bed Rail Mounting Plate (Passenger) (1)
- B. Bed Rail Mounting Plate (Driver) (1)
- C. Top Crossbar (3)
- D. Accessory Side Panel (4)
- E. Rack Upright (Half or Full Height) (6)
- F. Rear Grab Handle (2)
- G. Tactik Lock & Roll Up Tonneau Cover Mounting Bracket (6)
- H. Tactik Low Profile Tri-Fold Tonneau Cover Mounting Bracket (4)
- I. Bed Rail Mounting Spacer Block (8)
- J. Trail Rail Screw Plate (8)
- K. M6 Large Flat Washer (8)
- L. M10 Flat Washer (140)
- M. M10 Nyloc Hex Nut (72)
- N. M10 Hex Drive Button Head Screw (68)
- O. M6x30mm Hex Head Bolt (8)
- P. M6x60mm Hex Head Bolt (8)

TOOLS NEEDED:

- Safety Glasses
- Gloves
- 10mm Socket
- 13mm Deep Well Socket
- 17mm Deep Well Socket
- Ratchet
- 17mm Box Wrench
- 6mm Hex Key
- Masking Tape
- M6 x 1.0 Thread Chaser/Thread Tap

INSTALLATION WITH COMPATIBLE TONNEAU COVER

If you are planning on installing with compatible Tonneau cover, please reference the Lost Canyon Base Camp Bed Rack with Tonneau Cover Instruction Sheet supplemental information. This Sheet can be found on Quadratec's Website at Quadratec.com.

Fitment Compatibility:

Half Cab Rack:

Tactik Lock & Roll Up Tonneau - (P/N 12074-1300)

Full Cab Rack:

Tactik Lock & Roll Up Tonneau - (P/N 12074-1300)

Tactik Low Profile Tri-Fold Tonneau - (P/N 12047-1000)



INSTRUCTIONS: STEP 1

FIG 1



FIG 2



Put on gloves and safety glasses. Remove any items or accessories from inside bed that would interfere with the Bed Rack Installation. Apply masking tape to each side of the bed just below plastic bed caps. Two layers of tape is recommended. The tape will be removed after installation is complete. (FIG 1) For all Factory Bed Configurations without Mopar Trail Rail System re-tap the four (4) M6 mounting points located under plastic bed caps with an M6x1.0 tap. Repeat for the opposite side bed side. (FIG 2)

Note: If not equipped with Trail Rail System proceed to **STEP 5**.

STEP 2

FIG 3



FIG 4



If equipped with factory Trail Rail System slide four (4) M6 nut plates into each side. (FIG 3) Slide Nut Plates to be lined up in front of Factory Trail Rail System mounting bolts going into the inner bed. Short M6 bolt can be used to help slide Nut Plates into position. Remove bolts before proceeding to "**STEP 3**". (FIG 4)

STEP 3



Place the LH and RH Bed Mounting Brackets onto plastic bed caps. Taking care to clear the outer body and paint. (FIG 5) Secure each Bed Mounting Brackets with Four (4) Short M6x30mm bolts and M6 Flat Washers into the Trail Rail Nut Plates. (FIG 6) Repeat this Process for opposite side bed rail.

STEP 4

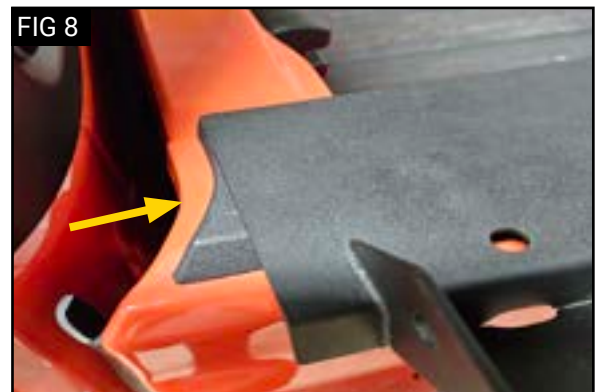
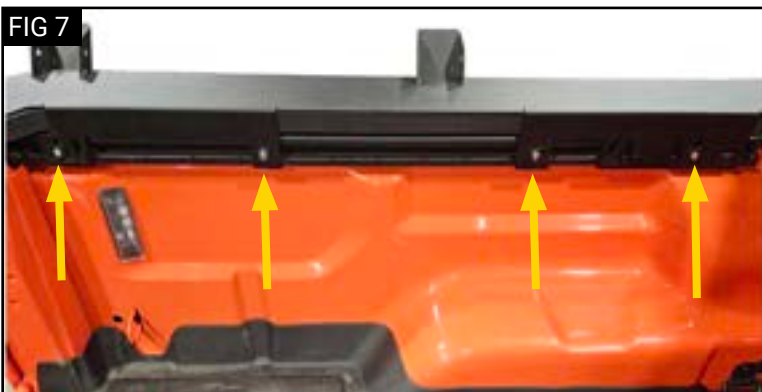

Loosely tighten each Bed Mounting Bracket allowing it to slide on plastic bed cap. (FIG 7) Align Bed Rack Mounting Base with the edge of plastic bed cap at front bulkhead on each side. (FIG 8)

STEP 5 - STANDARD BED INSTALLATION

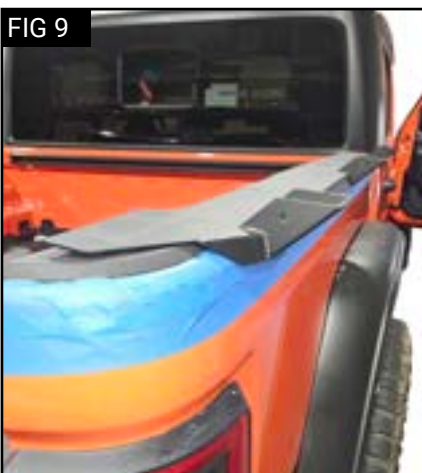

Place the LH and RH Bed Mounting Brackets onto plastic bed caps. Taking care to clear the outer body and paint. (FIG 9) Align Bed Mounting Brackets with factory bed mounting points. Install Rack Mounting Spacer Blocks using four (4) Long M6x60mm Bolts and four (4) M6 Flat Washers. (FIG 11) Base of Rack Mounting Spacer Block need to facing towards bed wall, and the bracket legs towards the Bed Rack Mounting Bracket. (FIG 10 & 11)

FIG 12



FIG 13

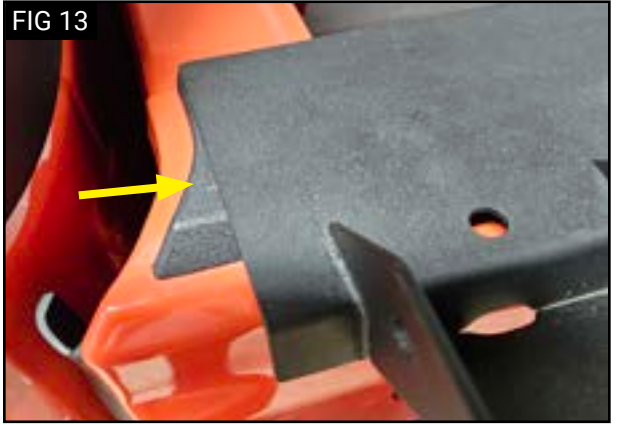

Loosely tighten each Bed Mounting Bracket allowing it to slide on plastic bed cap. (FIG 12) Align Bed Rack Mounting base with edge of Plastic Bed Cap at the front bulkhead. (FIG 13)

STEP 7

FIG 14

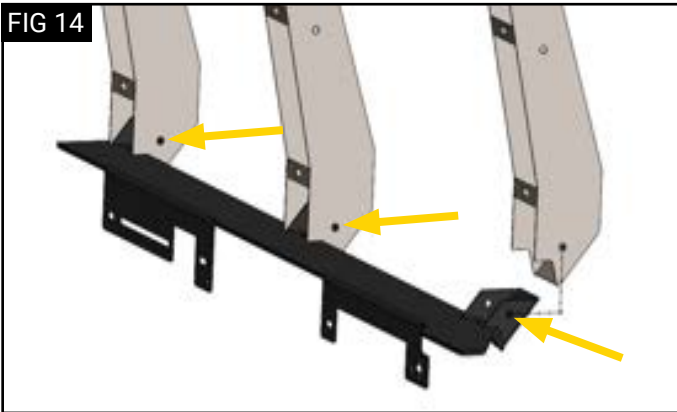
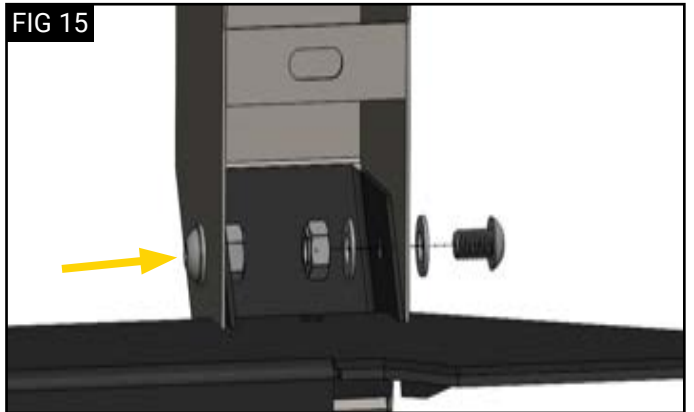

FIG 15



Begin placing each of the Bed Rack Uprights on their matting Bed Rail Mounting Bracket standoffs making sure that each Upright aligns with the mounting holes. (FIG 14) Next, on each side of the Upright secure it with a M10 Hex Drive Button Head Screw and M10 Flat Washer. Then on the inside place a M10 Flat washer and M10 Nyloc Hex Nut. (FIG 15) Using a 17mm Box Wrench and 6mm Hex Key begin to loosely tighten this hardware to allow for further adjustment during the rest of the assembly, **Do Not** fully tighten at this time.

STEP 8

FIG 16



FIG 17

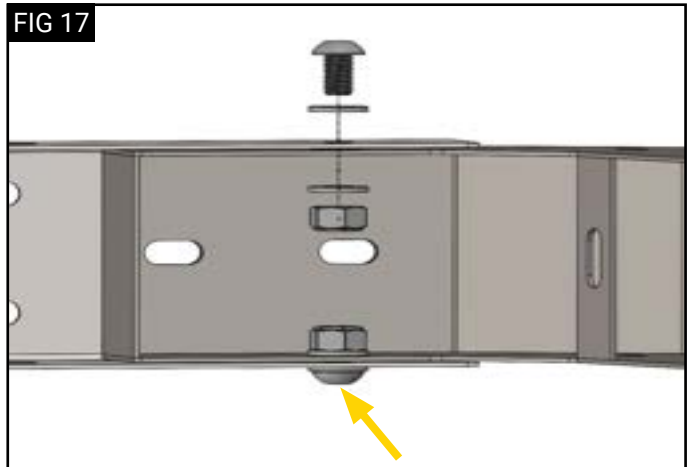

Place each of the Bed Rack Crossmembers on their matting Uprights ensuring each of the Crossmembers aligns with the mounting holes on the Uprights. (FIG 16) **Note:** One (1) Crossmembers has a Lost Canyon Logo applied to it, this Crossmember is to be placed on the rear most uprights. (FIG 16) Next on each side of the Crossmember secure it with a M10 Hex Drive Button Head Screw and a M10 Flat Washer. Then on the inside place a M10 Flat washer and M10 Nyloc Hex Nut. (FIG 17) Using a 17mm Box Wrench and 6mm Hex Key begin to loosely tighten this hardware to allow for further adjustment during the rest of the assembly, **Do Not** fully tighten at this time. Repeat this process for each crossmember connection.

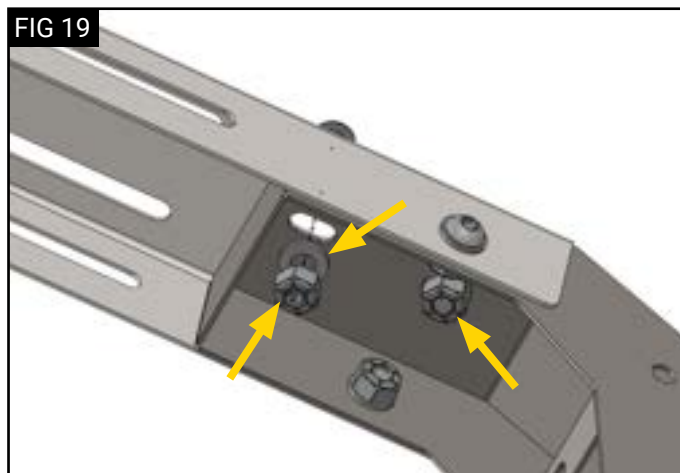
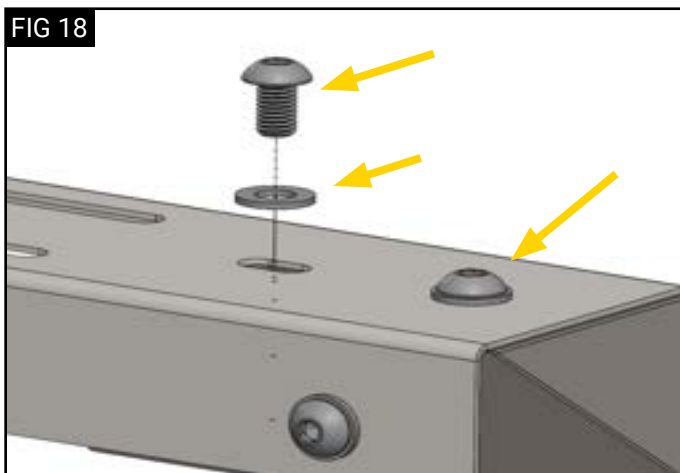

Next on the top side of the Crossmember secure each slot with a M10 Hex Drive Button Head Screw and a M10 Flat Washer through the Crossmember and the side Upright. (FIG 18) Then on the inside of the Upright place a M10 Flat washer and M10 Nyloc Hex Nut. (FIG 19) Using a 17mm Deep Well Socket and ratchet and 6mm Hex Key, begin to loosely tighten this hardware to allow for further adjustment during the rest of the assembly, **Do Not** fully tighten at

STEP 10

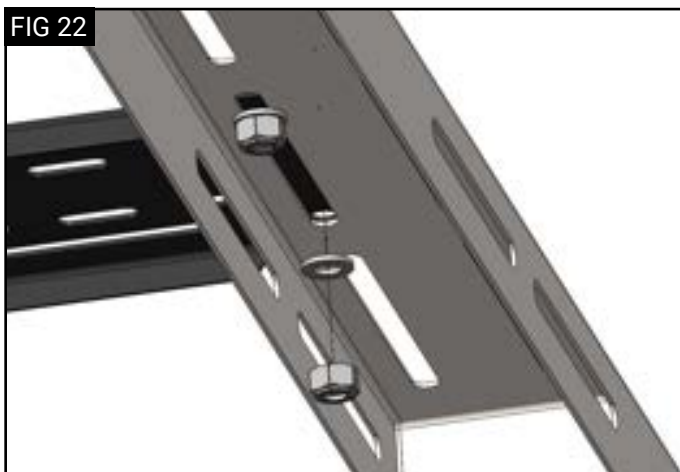
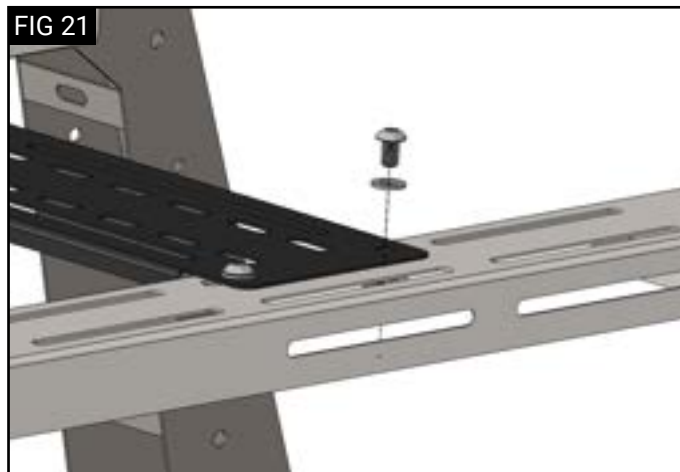

Place four (4) of the Accessory Panels on top of the Bed Rack Crossmembers. There are multiple adjustment slots in the Crossmembers allowing for many different configurations based on your accessory needs. (FIG 20) Next on each corner of the Accessory Panel secure it to the Crossmember with a M10 Hex Drive Button Head Screw and a M10 Flat Washer. (FIG 21) Then on the inside of the crossmember use a M10 Flat washer and M10 Nyloc Hex Nut. (FIG 22) Using a 17mm Deep Well Socket and Ratchet and 6mm Hex Key begin to loosely tighten this hardware to allow for further adjustment during the rest of the assembly, **Do Not** fully tighten at this time. Repeat this process for each end of the Accessory Panels.

STEP 11

FIG 23

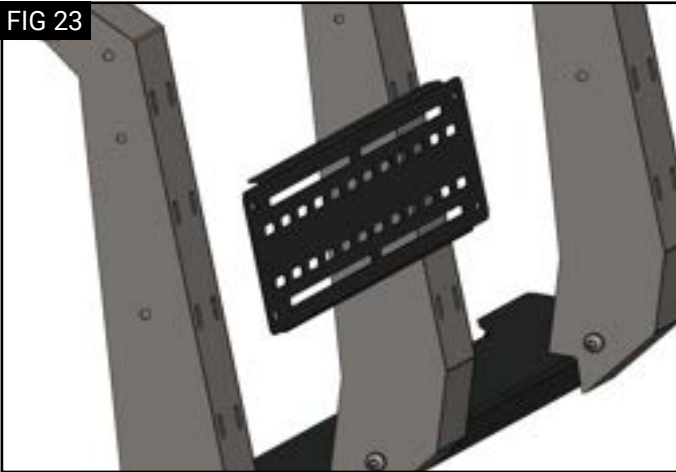

FIG 24

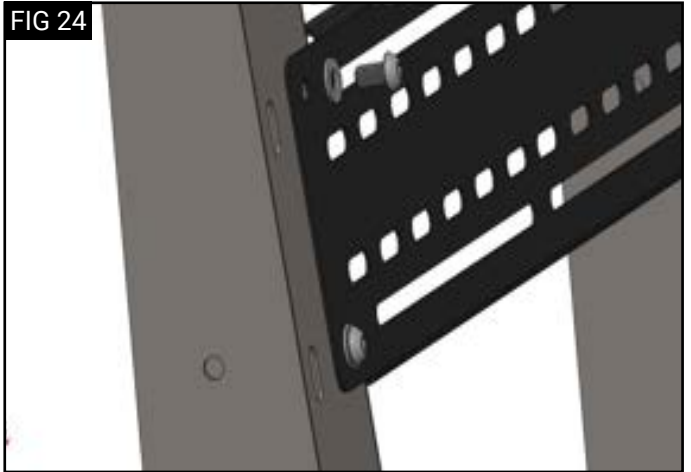
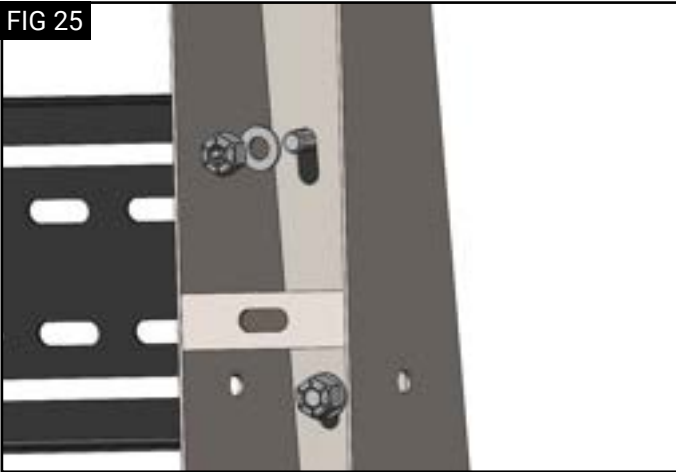

FIG 25



Place one of the Accessory Panels on side of the Bed Rack between the Uprights aligning with the configurations you desire. There are multiple adjustment slots in the Uprights allowing for many different configurations based on your accessory needs. (FIG 23) Next on each corner of the Accessory Panel secure it to the Upright with a M10 Hex Drive Button Head Screw and a M10 Flat Washer. (FIG 24) Then on the inside of the Upright use a M10 Flat washer and M10 Nyloc Hex Nut. (FIG 25) Using a 17mm Deep Well Socket and Ratchet and 6mm Hex Key begin to loosely tighten this hardware to allow for further adjustment during the rest of the assembly, **Do Not** fully tighten at this time. Repeat this process for each end of the Accessory Panels around the

STEP 12

FIG 28



After all final adjustments are made to the Base Camp Bed Rack and all of your Accessory Panels are in place continue to tighten all of the M10 Hex Drive Button Head bolts and Nyloc Nuts on their backsides. Using a combination of either a 17mm Open End Box Wrench or 17mm Deep Well Socket and ratchet with a 6mm Hex Key tighten all Bolts at each connection point.

Note: For all M6 Hardware torque to 11.8 (Nm) or 8.7 (ft*lb), for all M10 Hardware torque to 47.5 (Nm) or 35 (ft*lb).



Lastly install the two (2) Rear Grab Handles. Place the Grab Handle Studs through the rear most Crossmember. (FIG 29) Then on the inside of the Upright place a M10 Flat washer and M10 Nyloc Hex Nut on the Grab Handle Stud. (FIG 30) Using a 17mm Box Wrench, begin to tighten this hardware and firmly tighten, securing the Grab Handle. Repeat this process for the opposite Grab Handle.

Note: For all M6 Hardware torque to 11.8 (Nm) or 8.7 (ft*lbf), for all M10 Hardware torque to 47.5 (Nm) or 35 (ft*lbf).

Lost Canyon Exclusive Three Year Limited Warranty

Your Lost Canyon branded accessories are covered by the following Limited Warranty provided exclusively by Lost Canyon, 1028 Saunders Lane, West Chester PA 19380.

This **Limited Warranty** is the only warranty made in connection with your purchase. Lost Canyon neither assumes nor authorizes any vendor, retailer or other person or entity to assume for it any other obligation or liability in connection with this product or Limited Warranty. This Limited Warranty does not apply and is not cumulative to any accessory or part distributed by Lost Canyon for which the Manufacturer provides a separate written warranty.

What is Covered:

Subject to the terms, exclusions and limitations herein and with respect only to Lost Canyon branded accessories first sold in the United States, Lost Canyon warrants to the initial retail purchaser only that your Lost Canyon accessory shall be free of defects in material and workmanship: for a period of three (3) years from date of retail purchase.

This **Limited Warranty** is not assignable and shall terminate upon sale of the vehicle upon which the Lost Canyon accessory is installed or other transfer to third persons.

All other warranties are hereby disclaimed, except to the extent prohibited by applicable law in which case any implied warranty of merchantability or fitness for a particular purpose on this product is limited to three (3) years from date of initial retail sale. Lost Canyon reserves the rights to: (a.) require invoice or other proof your accessory is within the terms of this **Limited Warranty** as a condition of warranty service and, (b.) make future revisions to this product and **Limited Warranty** without prior notice or obligation to upgrade your product.

What is Not Covered:

Your Lost Canyon Limited Warranty does not cover products or parts Lost Canyon determines to have been damaged by or subjected to: (a.) **installation damage, alteration, modification, combination with other parts, failure to maintain or improper repair or service, (b.) normal wear & tear, cosmetic damage or damage from moisture or water immersion, (c.) Acts of God, accidents, misuse, negligence, inadequate mounting or impact with vehicle(s), obstacles or other aspects of the environment, (d.) theft, vandalism or other intentional damage.**

Remedy Limited to Repair/Replacement:

The exclusive remedy provided hereunder shall, upon Lost Canyon inspection and at our option, be either repair or replacement of product or parts (new or refurbished) covered under this Limited Warranty. Customers requesting warranty consideration should first contact Lost Canyon to obtain a RGA number (610-701-3336). All labor, removal, shipping, and installation costs are customer's responsibility.

Other Limitations - Exclusion of Damages - Your Rights Under State Law:

In consideration of the purchase price paid, neither Lost Canyon nor any independent Lost Canyon distributor/licensee are responsible for any time loss, rental costs, or for any incidental, consequential, punitive, or other damages you may have or incur in connection with any part or product purchased. Your exclusive remedy hereunder for covered parts is repair/replacement as described above.

This **Limited Warranty** gives you specific rights. You may also have other rights that vary from state to state. For example, some states do not allow limitations of how long an implied warranty lasts and /or do not allow the exclusion or limitation of incidental or consequential damages, so the limitations and exclusions herein may not apply to you.

©Lost Canyon, 2022. All Rights Reserved.
A4 Version 5/11/22

Instructions Part #12999.31217

